

MV-1 Series

Miniature Vaporizing Pressure Regulator

Introduction

The MV-1 Series Miniature Vaporizing Regulator is one of the smallest envelopes in the industry. Weighing in at a scant 0.86 pounds, the MV-1 is designed to supply heat to samples entering instrumentation systems where space is at a premium and quality cannot be compromised. It can be used to preheat liquids, to prevent condensation of gases or to vaporize liquids prior to gas analysis.

The pressure control section of the MV-1 is patterned after the time-tested design of our CPR-1 and provides the same excellent outlet pressure stability. The heating plate utilizes GO Regulator's unique heating element and incorporates an optional Thermal Cutout Device (TCO). This device prevents any exposed surface of the unit from exceeding 200° C under normal or fault conditions and is exclusive to GO Regulator's line of electrically heated vaporizing regulators. Offered in both 12 VDC and 24 VDC, the MV-1 Series offers the utmost in unequalled system safety and performance.



pressure regulators

Typical Applications

Analytical process sample conditioning systems:

- Petrochemical refineries
- Chemical production facilities
- Pilot plants (chemical & petrochemical)
- Portable low voltage analyzers

Technical Data

CONSTRUCTION	316L stainless steel
OUTLET PRESSURES	0-10, 0-25, 0-50, 0-100, 0-250, and 0-500 psig
OPERATING TEMPERATURE	up to 380° F (193° C)
HEATING CAPACITY RANGES (IN WATTS)	40 and 100

Features & Benefits

- Electro polished body with better than 25 Ra finish in diaphragm cavity for an optimal sealing surface
- Bubble-tight shutoff
- Unique *Spiro-Wind* heating element provides exceptionally even heating
- Available in 12 VDC and 24 VDC
- Optional TCO heating cartridge and proportional controller

GO Regulator

405 Centura Court • PO Box 4866 (29305) • Spartanburg, SC 29303
Phone (864) 574-7966 Fax (864) 574-5608
www.goreg.com • sales@goreg.com

MV-1 Series

How to Order

Standard items in bold

MV - 1 A B 2 3 B 3 E H D 1

BODY MATERIAL

1 316L stainless steel
4 Monel®

PORT CONFIGURATION

A Standard
For more configurations, see page 33

PORT TYPE

0 1/8" FNPT (all ports)
A 1/6" FNPT (all ports)
B 1/8" FNPT inlets; 1/6" FNPT outlets

TEMPERATURE RANGE

1 55° F to 85° F
2 75° F to 175° F
3 130° F to 300° F
4 260° F to 380° F (Non TCO units only)

HEATER WATTAGE

1 40W
2 40W with thermal cutout (TCO)
3 100W
4 100W with thermal cutout (TCO)

HEATER VOLTAGE

B 12 VDC
C 24 VDC

CAP STYLE

1 Tamper-proof, stainless steel
4 Tamper-proof, panel mount, stainless steel

CAVITY O-RING MATERIAL

D Viton®
I PTFE

SEAT MATERIAL

A Tefzel®
B CF PTFE
C Polyimide
H PCTFE (formerly Kel-F® 81)
Q PEEK™

OUTPUT RANGE

C 0-10 psig
D 0-25 psig
E 0-50 psig
G 0-100 psig
I 0-250 psig
J 0-500 psig

FLOW COEFFICIENT (Cv)

3 0.06
C 0.025

NOTE: The choices above represent an abbreviated list of the more commonly ordered options. For a complete listing of all available options, please see the Selection Wizard on the GO website at www.goreg.com or contact the factory.

Maximum Temperature & Operating Inlet Pressures

SEAT MATERIAL	MAXIMUM PRESSURE	@	MAXIMUM OPERATING INLET PRESSURE
Tefzel®	Up to 175° F (80° C)	@	3600 psig (24.82 MPa)
	176° F to 300° F (80° C to 148° C)	@	1000 psig (6.90 MPa)
	301° F to 380° F (148° C to 193° C)	@	400 psig (2.76 MPa)
High density PTFE	Up to 175° F (80° C)	@	3600 psig (24.82 MPa)
	176° F to 300° F (80° C to 148° C)	@	1000 psig (6.90 MPa)
	301° F to 380° F (148° C to 193° C)	@	400 psig (2.76 MPa)
PCTFE (formerly Kel-F®)	Up to 380° F (193° C)	@	3600 psig (24.82 MPa)
Polyimide	Up to 380° F (193° C)	@	3600 psig (24.82 MPa)
PEEK™	Up to 380° F (193° C)	@	3600 psig (24.82 MPa)

MV-1 Series

Outline and Mounting Dimensions

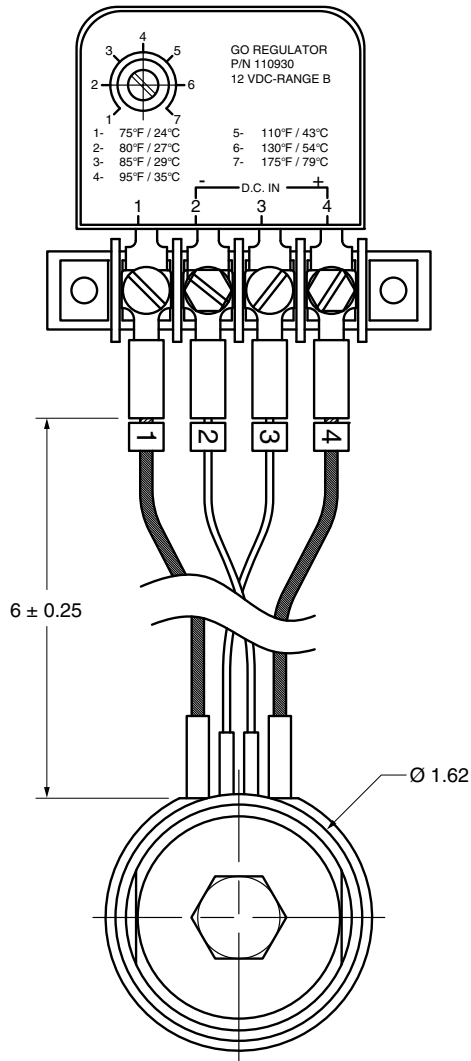

Weight = 0.86lbs

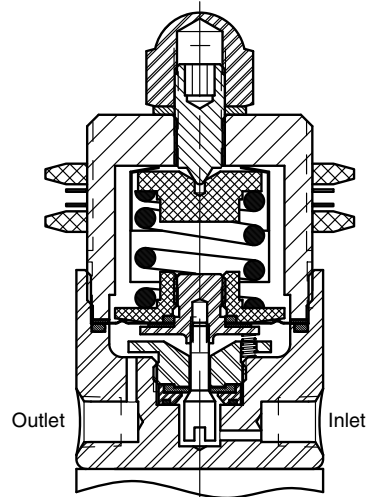
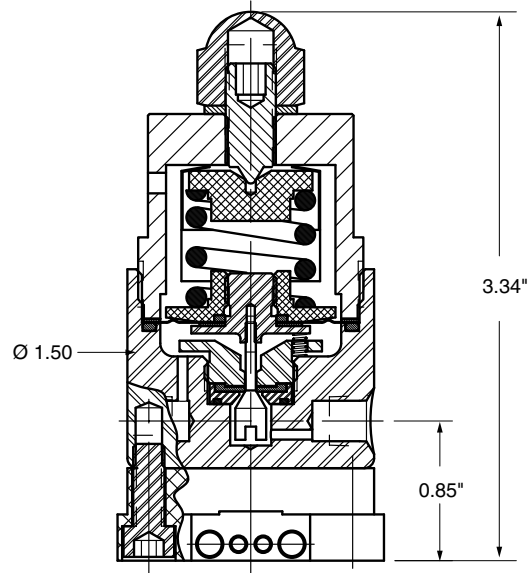

0.06 Cv and Panel Mount Options

Panel mount option requires
1.39 (35.3mm) minimum
diameter panel cut out