

LNG Series

Sample Vaporizer

Introduction

The heart of the LNG Vaporizer Assembly is the well-known HPR-2 Series heated pressure control valve. This unit has been used in many successful applications requiring heating of a process stream sample prior to analysis to prevent freeze up or for vaporization. The HPR-2 is a modularized unit consisting of a heated section and pressure control section. A field demonstration has now shown this vaporizer assembly to be serviceable in the vaporization of LNG product for analytical purposes and that homogeneous samples can be obtained under steady state operating conditions.

The HPR-2 pressure control valve is contained in a painted, insulated sheet metal enclosure and combined with an insulated input line plus a pressure gauge and relief valve. The heater section of the electric version is equipped with a thermostat for temperature control and is constructed to meet standard Division 1 Electrical Code requirements.

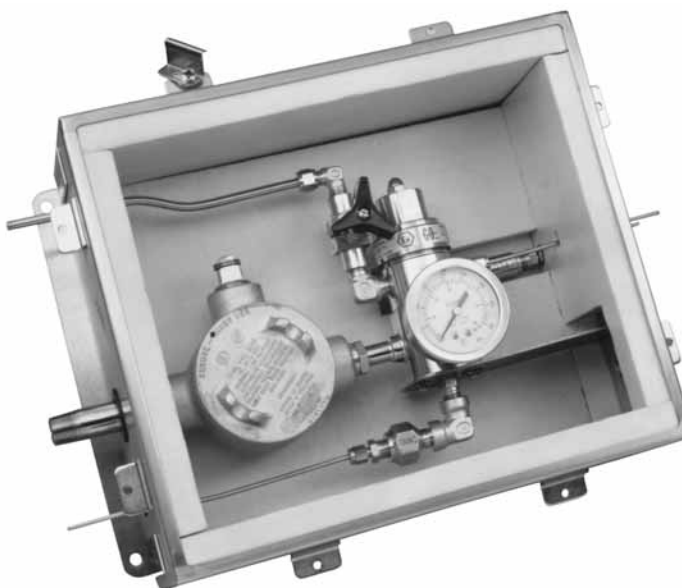

pressure regulators

Typical Applications

- LNG loading and off-loading points
- Petrochemical refineries
- Chemical production facilities
- Natural gas pipelines

Technical Data – Steam Heated

CONSTRUCTION	316L stainless steel
OUTLET PRESSURES	0–10, 0–25, 0–50, 0–100, 0–250, and 0–500 psig
INLET PRESSURE	up to 6000 psig at 380° F (193° C)
OPERATING TEMPERATURE	up to 550° F (285° C)
C _v COEFFICIENTS	0.06, 0.025, 0.2
INLET CONNECTIONS	1/8" FNPT
OUTLET CONNECTIONS	1/4" FNPT

Features & Benefits

- Optional Hastelloy® C-276 and Monel®
- Electropolished body with better than 25 Ra finish in diaphragm cavity for an optimal sealing surface
- Bubble-tight shutoff
- Modular pressure control and heat exchanger assemblies for easy maintenance
- Unique spiral wrapped heat exchange element provides up to 100 square inches of heat transfer area.
- Available in 120VAC or 240VAC and steam-heated
- Optional TCO heating cartridge and proportional controller

Technical Data – Electrically Heated

CONSTRUCTION	316L stainless steel
OUTLET PRESSURES	0–10, 0–25, 0–50, 0–100, 0–250, and 0–500 psig
INLET PRESSURE	up to 6000 psig at 380° F (193° C)
HEATING CAPACITY RANGES (IN WATTS)	40, 50, 100, and 150
C _v COEFFICIENTS	0.06, 0.025, 0.2
CERTIFICATIONS	CSA certification # LR-82566-5 ATEX Directive 94/9/EC Certification # TRLO3ATEX11001X

GO Regulator

405 Centura Court • PO Box 4866 (29305) • Spartanburg, SC 29303

Phone (864) 574-7966 Fax (864) 574-5608

www.goreg.com • sales@goreg.com

LNG Series

How to Order

Standard items in bold

10283 C 2 3 3 1 2 2

BASIC PART NUMBER

- 102830** 0–10 psig electronically heated
- 102831** 0–25 psig electronically heated
- 102832** 0–50 psig electronically heated
- 102833** 0–100 psig electronically heated
- 102834** 0–250 psig electronically heated
- 102835** 0–500 psig electronically heated
- 109551** 0–25 psig steam heated
- 109552** 0–50 psig steam heated
- 109553** 0–100 psig steam heated
- 109554** 0–250 psig steam heated
- 109555** 0–500 psig steam heated

SEAT MATERIAL

- A** Tefzel®
- B** CF PTFE
- C** Polyimide
- Q** PEEK™

WATTAGE

- 1** 40 watts
- 2** 50 watts
- 3** **100 watts**
- 4** 150 watts
- 5** Steam heated

THERMISTOR TYPE

- 1** Thermally protected (TCO)
- 2** **Non-thermally protected**
- 5** **Steam**

CONTROLLER TYPE

- 1** **On/Off**
- 2** Proportional
- 5** **Steam**

CONFIGURATION

- 1** **Standard enclosure (painted steel)**
- 2** Stainless steel enclosure
- 3** Standard enclosure, all ¼" tube
- 4** Stainless steel enclosure, all ¼" tube
- 5** Standard enclosure, ¼" tube bulkhead
- 6** Stainless steel enclosure, ¼" tube bulkhead

HEATER BLOCK TYPE

- 1** **Steam**
- 2** Steam, HPR-2XW
- 3** **120 VAC**
- 4** **240 VAC**
- 6** 120 VAC, HPR-2XW
- 7** 240 VAC, HPR-2XW

TEMPERATURE RANGE

- 1** 55° F to 85° F
- 2** **75° F to 175° F**
- 3** **130° F to 300° F**
- 4** 260° F to 380° F
- 5** **Steam heated**

NOTE: The choices above represent an abbreviated list of the more commonly ordered options. For a complete listing of all available options, please see the Selection Wizard on the GO website at www.gore.com or contact the factory.

Maximum Temperature & Operating Inlet Pressures

HPR-2 Electric or Steam 2-piece Assembly

(Heater block and regulator body separate)

SEAT MATERIAL	MAXIMUM PRESSURE	@	MAXIMUM OPERATING INLET PRESSURE
Tefzel®	Up to 175° F (80° C)	@	3600 psig (24.82 MPa)
	176° F to 300° F (80° C to 148° C)	@	1000 psig (6.90 MPa)
	301° F to 380° F (148° C to 193° C)	@	400 psig (2.76 MPa)
High density PTFE	Up to 175° F (80° C)	@	3600 psig (24.82 MPa)
	176° F to 300° F (80° C to 148° C)	@	1000 psig (6.90 MPa)
	301° F to 380° F (148° C to 193° C)	@	400 psig (2.76 MPa)
PCTFE (formerly Kel-F®)	Up to 380° F (193° C)	@	3600 psig (24.82 MPa)
Polyimide	Up to 380° F (193° C)	@	3600 psig (24.82 MPa)
PEEK™	Up to 380° F (193° C)	@	3600 psig (24.82 MPa)

HPR-2 Electric or Steam 1-piece Assembly

(Integral heater block and regulator)

SEAT MATERIAL	MAXIMUM PRESSURE	@	MAXIMUM OPERATING INLET PRESSURE
Tefzel®	Up to 175° F (80° C)	@	3600 psig (24.82 MPa)
	176° F to 300° F (80° C to 148° C)	@	1000 psig (6.90 MPa)
	301° F to 380° F (148° C to 193° C)	@	400 psig (2.76 MPa)
High density PTFE	Up to 175° F (80° C)	@	3600 psig (24.82 MPa)
	176° F to 300° F (80° C to 148° C)	@	1000 psig (6.90 MPa)
	301° F to 380° F (148° C to 193° C)	@	400 psig (2.76 MPa)
PCTFE (formerly Kel-F®)	Up to 380° F (193° C)	@	3600 psig (24.82 MPa)
Polyimide	Up to 380° F (193° C)	@	6000 psig (24.82 MPa)
PEEK™	Up to 380° F (193° C)	@	6000 psig (24.82 MPa)

LNG Series

Outline & Mounting Dimensions

Electrical

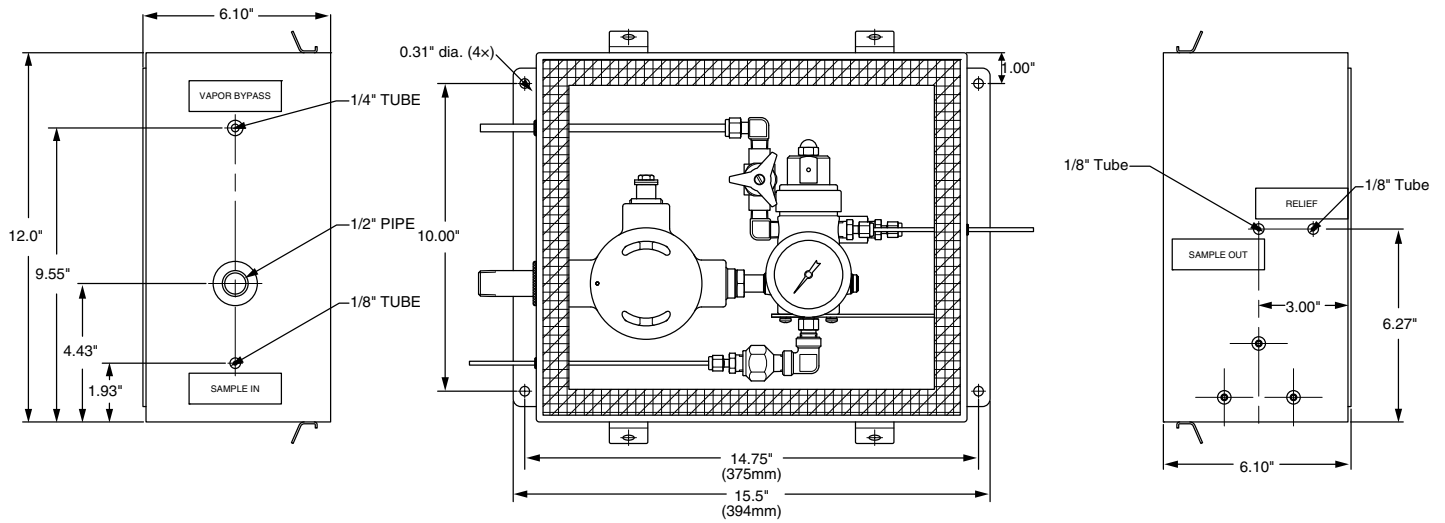

Steam

