

## GENERAL

**ALIASONIC** AUT8500 series is an intelligent handheld product, which provides quick and precise measurement of thickness for most industrial material.

AUT8500 series is widely used in various precise measurement for different hardware/parts in industrial realm and diffusely applied in manufacture fields, metal processing or commercial inspection.

## FEATURES

- Auto calibration to assure accuracy
- Low battery indication
- Preset or store more than ten sound velocity and thickness measurement data
- Auto power off if no operation within two minutes
- With a given thickness to measure the sound velocity
- Coupling status indication
- High / Low thickness buzzer alarm

## STANDARD SPECIFICATION

● <b>Model</b>	: <b>AUT8500A</b>
● Measuring Range	: 1.2 ~ 225.0 mm
● Resolution	: 0.1mm
● Min. limit for tube	: $\phi$ 20 * 3.0 mm ( $\phi$ 10 Transducer)
● Accuracy	: +/-1% of Reading +/-0.1mm
● Engineer unit	: mm
● Sound Velocity Range	: 1000 ~ 9999 m/s
● Accuracy of Velocity	: +/-1% of Reading (Thickness < 20mm) : +/-5% of Reading (Thickness > 20mm)
● Operating Temp.	: -20 to +60 °C
● Battery life	: 15 to 20 Hours
● Power Supply	: 1.5V AAA Battery * 3 pcs
● Power Consumption	: <0.54 W (with back light on)
● Standard Package	: : Ultrasonic Thickness Gauge : $\phi$ 10 Transducer (5MHz) : Ultrasonic Couplant : Sample Block : Leather Case Cover : Carrying Case

● <b>Model</b>	: <b>AUT8500B</b>
● Measuring Range	: 1.00 ~ 300.0 mm (1/25" ~ 12")
● Resolution	: 0.01mm
● Min. limit for steel tube	: $\phi$ 15 * 2.0 mm ( $\phi$ 6 Transducer) : $\phi$ 20 * 3.0 mm ( $\phi$ 10 Transducer)
● Accuracy	: +/-0.8% of Reading +/-0.05mm
● Engineer unit	: mm / Inch
● Sound Velocity Range	: 1000 ~ 9999 m/s
● Accuracy of Velocity	: +/-1% of Reading (Thickness < 20mm) : +/-5% of Reading (Thickness > 20mm)
● Alarm Setting	: High / Low Thickness Alarm With Buzzer
● Operating Temp.	: -20 to +60 °C
● Battery life	: 30 to 35 hours
● Power Supply	: 1.5V AAA Battery * 3 pcs
● Power Consumption	: <0.16W (with back light on)
● Standard Package	: : Ultrasonic Thickness Gauge : $\phi$ 10 Transducer (5MHz) : $\phi$ 6 Transducer (5MHz) : Ultrasonic Couplant : Sample Block : Leather Case Cover : Carrying Case



DESIGNS

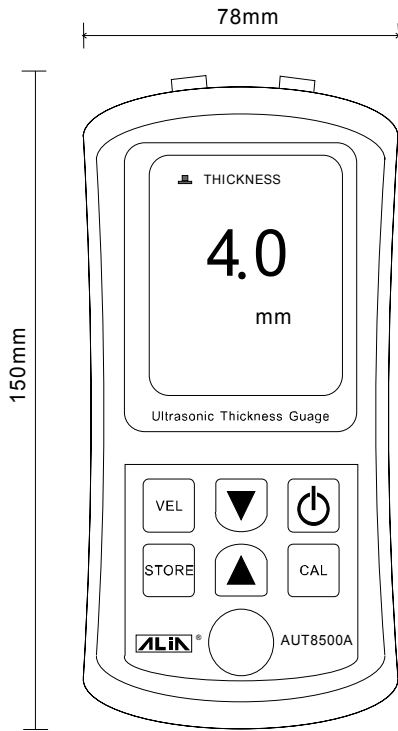

AUT8500A

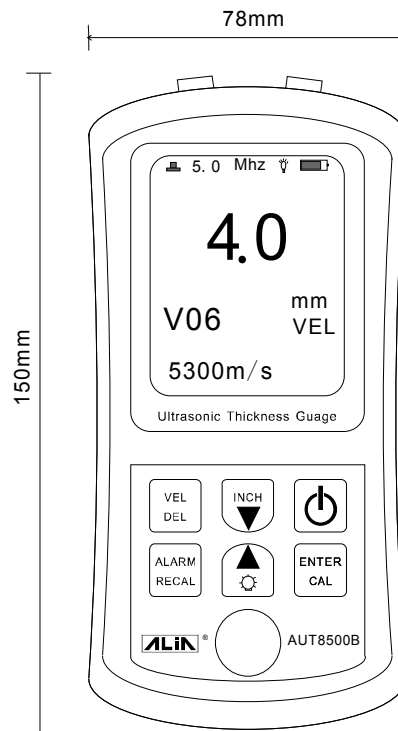

AUT8500B

ACCESSORIES



Ultrasonic Thickness Gauge



Couplant



Sample Block



Carrying Case



φ 10 Transducer



φ 6 Transducer